

推奨) 入口圧力を0.2Mpa以上確保して下さい。

A  
B  
C  
D  
E  
F

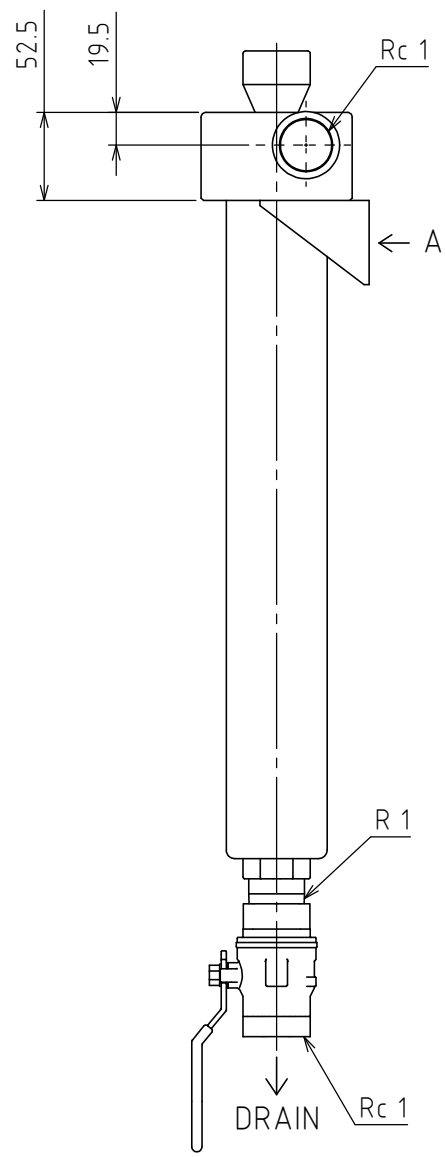
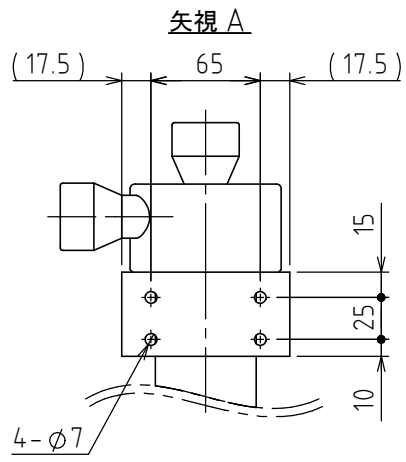
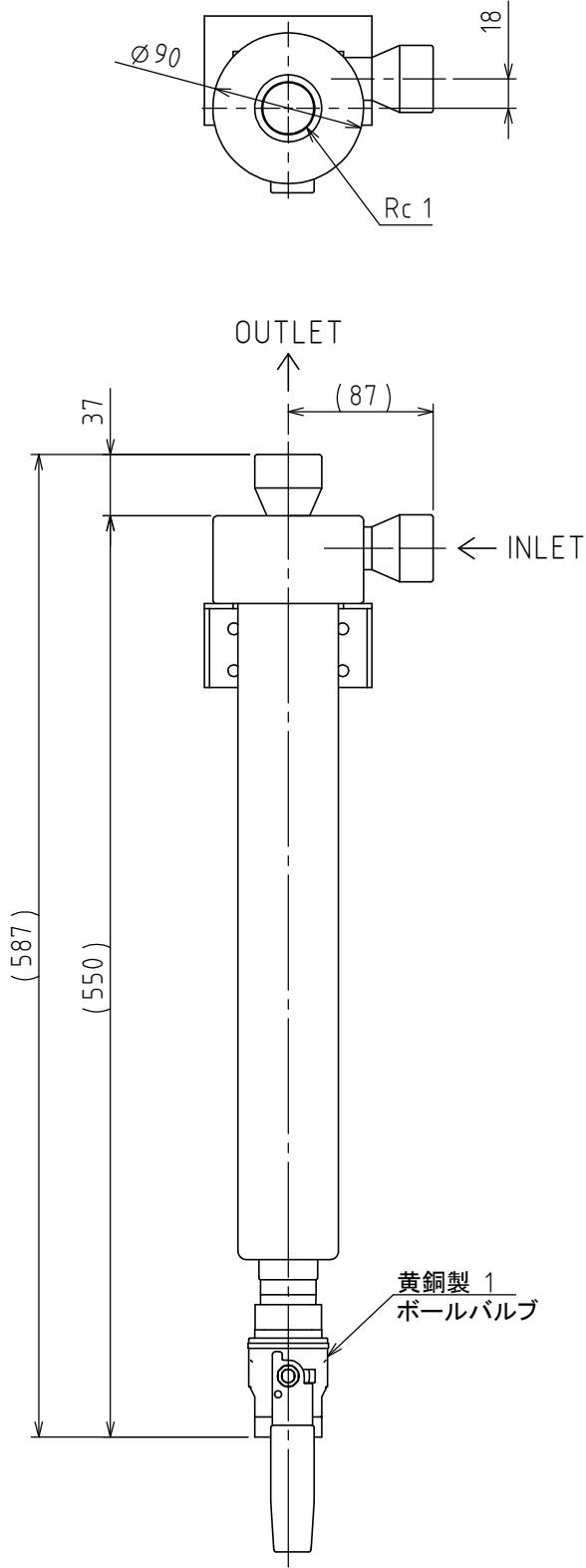

3						6							
2						5							
1						4							

APPROVED	CHECKED	DESIGNED	DRAWN
----------	---------	----------	-------

REV No.	DATE	SIGNATURE	CHECKED	REV NOTE	REV No.	DATE	SIGNATURE	CHECKED	REV NOTE		
mm	MATERIAL	SUS304			TITLE	KSM-25					
A 4	SURFACE TREATMENT				GROUP	手動					
HEAT TREATMENT						CODE No,	20120911				
SCALE				-	NUMBER			DWG No,	XXXX-XXXX-XX		

industria